

IXP-3N5520/4N5520 3N5515

Arm length **550mm**
Vertical axis **200mm**
Vertical axis **150mm**

Model Specification Items	Series	IXP	N	55	WA	P3			
	Number of axes	3: 3 axes 4: 4 axes	Arm length	20 :200mm 15GL :150mm 15GW :150mm	Gripper	Encoder type	Cable length	Applicable controller	Option
				*Refer to "Attached Gripper Types" for the types of grippers installed.					

*Controller is not included.



POINT
Note on selection

- Refer to P. 7 for *1 through *6.
- Make sure to select the brake option when the payload is 4kg or more.
- The vertical axis does not support push-motion control.
- The allowable push force should be 90N under condition of having a buffer such as a spring on a tool or the pressing side.
- Refer to P. 7 for the work envelope, and P. 8 for the notes on acceleration/deceleration setting.

*The photograph shows a 4-axis specification.

Robot Specifications

Axis configuration	Arm length (mm)	Work envelope	Positioning repeatability *1	Maximum operating speed in PTP mode *2			Payload (kg) *3	
				No gripper	With large gripper (GL)	With extra-large gripper (GW)	Rated	Maximum
Axis 1	Arm 1	260	±127°	2943mm/s (Composite speed)	2943mm/s (Composite speed)	2943mm/s (Composite speed)	2	6
Axis 2	Arm 2	290	±127°					
Axis 3	Vertical axis	—	200mm (Note 1)	±0.02mm	240mm/s	240mm/s	240mm/s	
Axis 4	Rotational axis	—	±360°	±0.02°	700°/s	—	—	
	Large gripper GL (Note 2)	—	22mm (Both fingers)	±0.01mm	—	125mm/s (One finger)	—	1.5 (Note 3)
	Extra-large gripper GW (Note 2)	—	30mm (Both fingers)	±0.01mm	—	—	157mm/s (One finger)	2.5 (Note 3)

(Note 1) When the extra-large gripper is installed, the work envelope of the vertical axis becomes 150mm. (Note 2) Refer to the gripper selection guide in our ROBO Cylinder General Catalog. (Note 3) This is the maximum payload on the gripper when it is attached to a SCARA Robot.

Robot Specifications

	3-axis specification	4-axis specification	3-axis specification	
	No gripper		With large gripper (GL)	With extra-large gripper (GW)
Encoder type	Battery-less absolute encoder *			
User wiring	AWG24×6, AWG26×5P (shielded) *User cables are sold separately. Refer to the operation manual for detail.		User wiring is not supported because the gripper wiring is used.	
User piping	O.D. ø4, I.D. ø2.5, 3 air tubes Maximum working pressure 0.8MPa			
Standard cycle time *4 (sec)	0.73		0.73 (When transporting 2kg including a gripper)	
Allowable torque (Axis 4) (N·m)	—	3.06	—	
Allowable moment (N·m)	9.4		Ma: 3.8 Mb: 5.5 Mc: 9.4	Ma: 9.4 Mb: 9.4 Mc: 9.4
Allowable inertial moment from the tip of the vertical axis *5 (kg·m ²)	Rated 0.01 Maximum 0.03	Rated 0.01 Maximum 0.01	Maximum 0.026	Maximum 0.024
Ambient operating temperature/humidity	Temperature 0 ~ 40°C Humidity 20 ~ 85%RH (Non-condensing)			
Unit weight (kg)	20	21	21.3	21.9

*The gripper is incremental type

Attached Gripper Types

IXP-3N5515GL	The large gripper RCP4-GRSLL is installed at the tip of the vertical axis.
IXP-3N5515GW	The extra-large gripper RCP4-GRSWL is installed at the tip of the vertical axis.

Option

Name	Option code	Reference page	Standard price
Brake	B	Refer to our ROBO Cylinder General Catalog	—

*Make sure to select the brake option when the payload is 4kg or more.

Price List

Specification	Model number	Standard price
3-axis specification	IXP-3N5520	—
3-axis specification with large gripper	IXP-3N5515GL	—
3-axis specification with extra-large gripper	IXP-3N5515GW	—
4-axis specification	IXP-4N5520	—

Cable Length <Per Axis*>

Type	Cable code	Standard price
Standard type	P (1m)	—
	S (3m)	—
	M (5m)	—
Specified length	X06 (6m) ~ X10 (10m)	—
	X11 (11m) ~ X15 (15m)	—
	X16 (16m) ~ X20 (20m)	—
Robot cable	R01 (1m) ~ R03 (3m)	—
	R04 (4m) ~ R05 (5m)	—
	R06 (6m) ~ R10 (10m)	—
	R11 (11m) ~ R15 (15m)	—
	R16 (16m) ~ R20 (20m)	—

*The 3-axis specification requires three cables, while the gripper specification and 4-axis specification require four cables.

Dimensions



CAD drawings can be downloaded from the website.

www.intelligentactuator.com

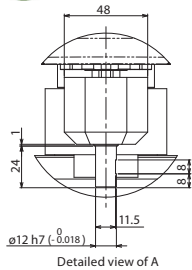

Detailed view of A

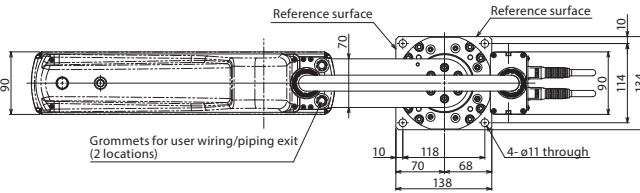

Grommets for user wiring/piping exit (2 locations)

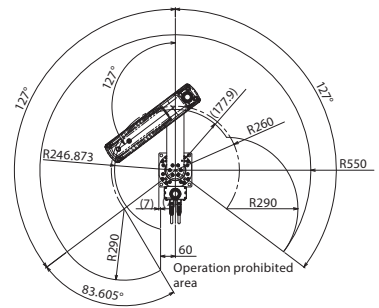

Work envelope of the right-arm system

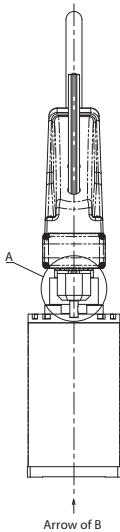

Arrow of B

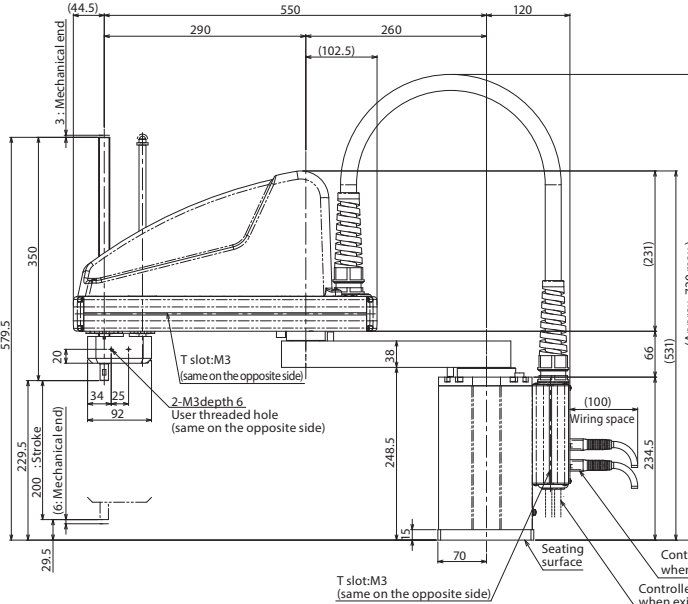

T slot:M3 (same on the opposite side)

Controller cables when exiting from the rear panel

Controller cables when exiting through grommet

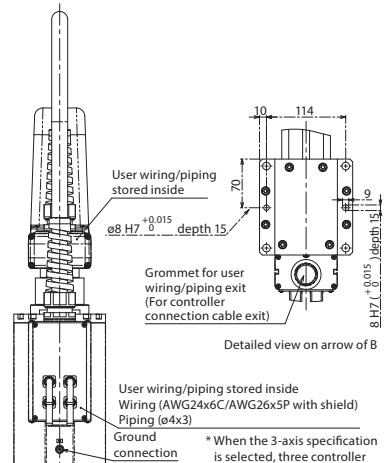

Detailed view on arrow of B

User wiring/piping stored inside
Wiring (AWG24x6C/AWG26x5P with shield)
Piping (ø4x3)
Ground connection

*When the 3-axis specification is selected, three controller cables are needed.

<Gripper Specification>

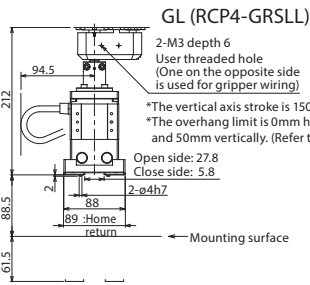

GL (RCP4-GRSLL)
2-M3 depth 6
User threaded hole (One on the opposite side is used for gripper wiring)
*The vertical axis stroke is 150mm.
*The overhang limit is 0mm horizontally and 50mm vertically. (Refer to P7 *6.)
Open side: 27.8
Close side: 5.8
2-ø4h7
89 :Home return
Mounting surface

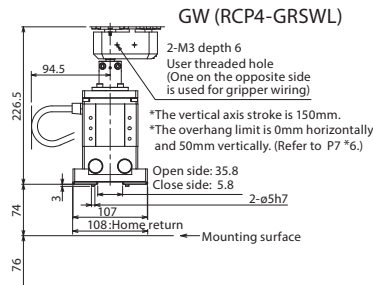
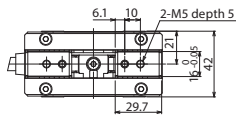

GW (RCP4-GRSWL)
2-M3 depth 6
User threaded hole (One on the opposite side is used for gripper wiring)
*The vertical axis stroke is 150mm.
*The overhang limit is 0mm horizontally and 50mm vertically. (Refer to P7 *6.)
Open side: 35.8
Close side: 5.8
2-ø4h7
89 :Home return
Mounting surface

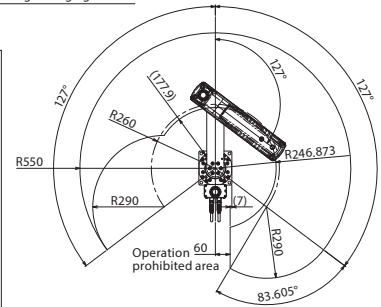
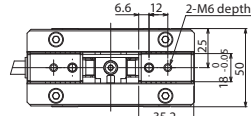

Work envelope of the left-arm system

Applicable Controller

IXP series robots can operate with the following controllers. Make sure to select the model depending on the purpose.

Name	External view	Maximum number of controlled axes	Supply voltage	Control method				Max. pos. points	Standard price	Reference page
				Position	Pulse train	Program	Network *Option			
MSEL-PCX/PGX		4	Single-phase 100V ~ 230V	-	-	•	DeviceNet CC-Link EtherNet/IP PROFINET EtherCAT	30000	-	→P37