

IXP-3N4515 / 4N4515 3N4510

Arm length
450mm

Vertical axis
100mm

Vertical axis
150mm

■ Model Specification Items	IXP	—	<input type="checkbox"/> N	45	<input type="checkbox"/>	—	WA	—	<input type="checkbox"/>	—	P3
	Series	Number of axes 3: 3 axes 4: 4 axes	Arm length 45: 450mm	Vertical axis stroke 15 :150mm 15GM :150mm 10GL :100mm	Gripper No gripper Medium gripper installed Large gripper installed	Encoder type WA: Battery-less absolute specification	Cable length N: None P: 1m S: 3m M: 5m	Applicable controller P3: MSEL			

*Controller is not included.
*Refer to "Attached Gripper Types" for the types of grippers installed.



POINT
Note on selection

- Refer to P. 7 for *1 through *5.
- The vertical axis has no brake.
The unique structure holds the load in place even when the servo is turned off.
- The vertical axis does not support push-motion control.
- The allowable push force is 60N under condition of having a buffer such as a spring on a tool or the pressing side.
- Refer to P. 7 for the work envelope, and P. 8 for the notes on acceleration/deceleration setting.

*The photograph shows a 4-axis specification.

Axis configuration		Arm length (mm)	Work envelope	Positioning repeatability *1	Maximum operating speed in PTP mode *2			Payload (kg) *3	
					No gripper	With medium gripper (GM)	With large gripper (GL)	Rated	Maximum
Axis 1	Arm 1	260	±127°	±0.03mm	2438mm/s (Composite speed)	2438mm/s (Composite speed)	2060mm/s (Composite speed)	1	3
Axis 2	Arm 2	190	±127°						
Axis 3	Vertical axis	—	150mm (Note 1)	±0.02mm	270mm/s	270mm/s	189mm/s		
Axis 4	Rotational axis	—	±360°	±0.02°	1000°/s	—	—	—	0.5 (Note 3)
	Medium gripper GM (Note 2)	—	14mm (Both fingers)	±0.01mm	—	94mm/s (One finger)	—		
	Large gripper GL (Note 2)	—	22mm (Both fingers)	±0.01mm	—	—	125mm/s (One finger)	—	1.5 (Note 3)

(Note 1) When the large gripper is installed, the work envelope of the vertical axis becomes 100mm. (Note 2) Refer to the gripper selection guide in our ROBO Cylinder General Catalog. (Note 3) This is the maximum payload on the gripper when it is attached to a SCARA Robot.

Robot Specifications		3-axis specification	4-axis specification	3-axis specification	
		No gripper		With medium gripper (GM)	With large gripper (GL)
Encoder type		Battery-less absolute encoder *			
User wiring		AWG24x6, AWG26x5P (shielded) *User cables are sold separately. Refer to the operation manual for detail.		User wiring is not supported because the gripper wiring is used.	
User piping		O.D. ø4, I.D. ø2.5, 3 air tubes (Maximum working pressure 0.8MPa)			
Standard cycle time *4 (sec)	SCARA	0.67		0.67	0.95
	Gripper (full stroke)	—		0.51	0.56
Allowable torque (Axis 4) (N·m)		—	1.4	—	
Allowable moment (N·m)		2.9		Ma: 1.9 Mb: 2.7 Mc: 2.9	Ma: 2.9 Mb: 2.9 Mc: 2.9
Allowable inertial moment from the tip of the vertical axis *5 (kg·m ²)		Rated 0.003 Maximum 0.01	Rated 0.003 Maximum 0.003	Maximum 0.002	Maximum 0.009
Ambient operating temperature/humidity		Temperature 0 ~ 40°C Humidity 20 ~ 85%RH (Non-condensing)			
Unit weight (kg)		13	14	13.5	14

*The gripper is incremental type

Attached Gripper Types	
IXP-3N4515GM	The medium gripper RCP4-GRSML is installed at the tip of the vertical axis.
IXP-3N4510GL	The large gripper RCP4-GRSLL is installed at the tip of the vertical axis.

Price List		
Gripper	SCARA 3-axis specification	Standard price
None	IXP-3N4515	—
Medium gripper	IXP-3N4515GM	—
Large gripper	IXP-3N4510GL	—
Gripper	SCARA 4-axis specification	Standard price
None	IXP-4N4515	—

Cable Length <Per Axis*>		
Type	Cable code	Standard price
Standard type	P (1m)	—
	S (3m)	—
	M (5m)	—
Specified length	X06 (6m) ~ X10 (10m)	—
	X11 (11m) ~ X15 (15m)	—
	X16 (16m) ~ X20 (20m)	—
Robot cable	R01 (1m) ~ R03 (3m)	—
	R04 (4m) ~ R05 (5m)	—
	R06 (6m) ~ R10 (10m)	—
	R11 (11m) ~ R15 (15m)	—
	R16 (16m) ~ R20 (20m)	—

*The 3-axis specification requires three cables, while the gripper specification and 4-axis specification require four cables.

Dimensions



CAD drawings can be downloaded from the website.

www.intelligentactuator.com

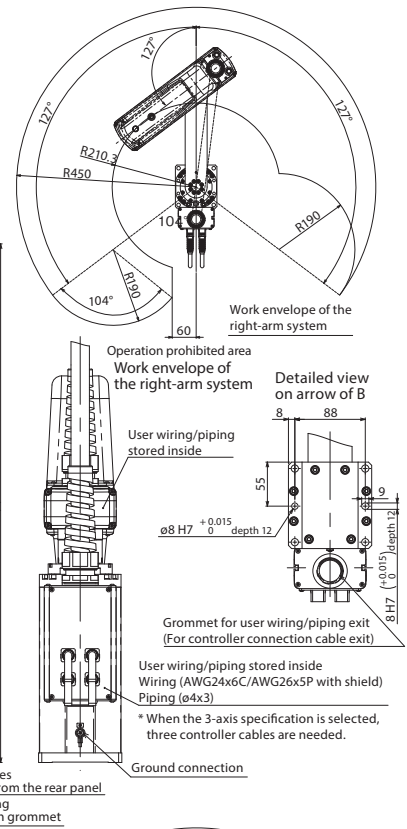
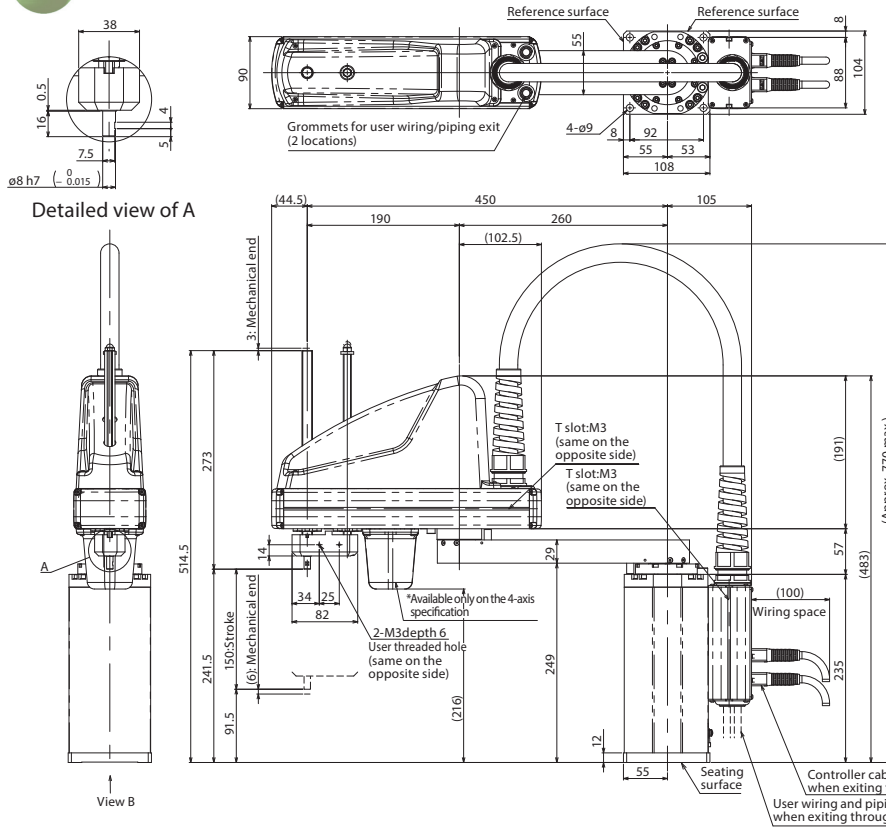

<Gripper Specification>

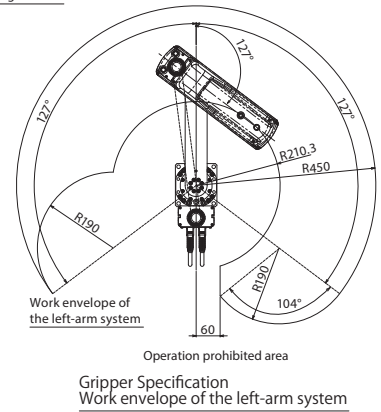
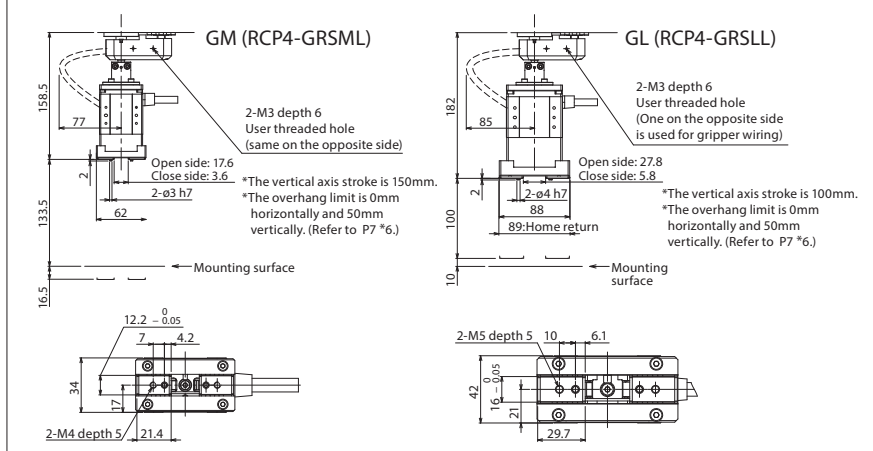

Applicable Controller

IXP series robots can operate with the following controllers. Make sure to select the model depending on the purpose.

Name	External view	Maximum number of controlled axes	Supply voltage	Control method				Max. pos. points	Standard price	Reference page
				Position	Pulse train	Program	Network *Option			
MSEL-PCX/PGX		4	Single-phase 100V ~ 230V	-	-	•	DeviceNet CC-Link PROFINET EtherNet/IP EtherCAT	30000	-	→P37