

IX-HNN5020[H]	Medium SCARA robot, Ceiling-mount type Arm length 500mm, Vertical axis 200mm [High-power specification]		
IX-INN5020[H]	Medium SCARA robot, Ceiling-mount inverse type Arm length 500mm, Vertical axis 200mm [High-power specification]		
Model items IX — □ NN5020[H] — □ — T2			
Series	Type	Cable length	Applicable controller
HNN5020[H] : Ceiling-mount type Arm length 500mm, Vertical axis 200mm	5L : 5 m (standard) 10L: 10 m	T2: XSEL-PX/QX	
INN5020[H] : Ceiling-mount inverse type Arm length 500mm, Vertical axis 200mm			



*For details on the model items, refer to page 8.

Model/Specifications

Model	Axis configuration	Arm length (mm)	Motor capacity (W)	Work envelope	Positioning Repeatability (mm) (Note 1)	PTP operation Maximum operating speed (Note 2)	Standard cycle time (sec) (Note 3)	Load capacity (kg) (Note 4)		Axis 3 (vertical axis) push force (N) (Note 5)		Axis 4 allowable load	
								Rated	Maximum	Maximum limit	Minimum limit	Allowable inertial moment (kg·m ²) (Note 6)	Allowable torque (N·m)
IX-HNN5020[H]-□-T2 IX-INN5020[H]-□-T2	Axis 1 Arm 1 Axis 2 Arm 2 Axis 3 Vertical axis Axis 4 Rotating axis	250 250 - -	400 200 200 100	±120° ±135° 200mm ±360°	±0.010 (XY) ±0.010 ±0.005	6283mm/s [6381mm/s] (Composite speed) 1393mm/s [1473mm/s] 1200°/s [1857°/s]	0.44 [0.39]	2	10	152.0 [181.0]	78.1 [93.0]	0.06	3.3 [3.7]

*In the model number above, specify the cable length in □.

*□ indicates the high-power specification type

*SCARA robots cannot operate continuously at 100% speed and acceleration. For details on the operating conditions, refer to Reference Acceleration/Deceleration Settings on page 44.

Common Specifications

Encoder type	Absolute
User wiring	25-conductor AWG26 D-sub/25-pin connector with shield (socket)
User tubing	Air tube (O.D. ø6, I.D. ø4) x 2 (Normal working pressure 0.8 MPa) Air tube (O.D. ø4, I.D. ø2.5) x 2 (Normal working pressure 0.8 MPa)
Alarm indicator (Note 7)	Small red LED indicator x 1 (24 V DC must be supplied.)
Brake-release switch (Note 8)	Allows remote release of Z-axis (24 VDC required)

Ambient temperature/humidity	Temperature: 0-40 °C, humidity: 20-85%RH or less (no condensation)
Unit weight	30.5Kg
Applicable controller	T2: XSEL-PX/QX
Cable length (Note 9)	5L: 5 m (standard), 10L: 10 m (optional)

Dimensions

*For the inverse type, the following illustrations should be turned upside down. (See page 2.)

The CAD drawings can be downloaded from our Web site.

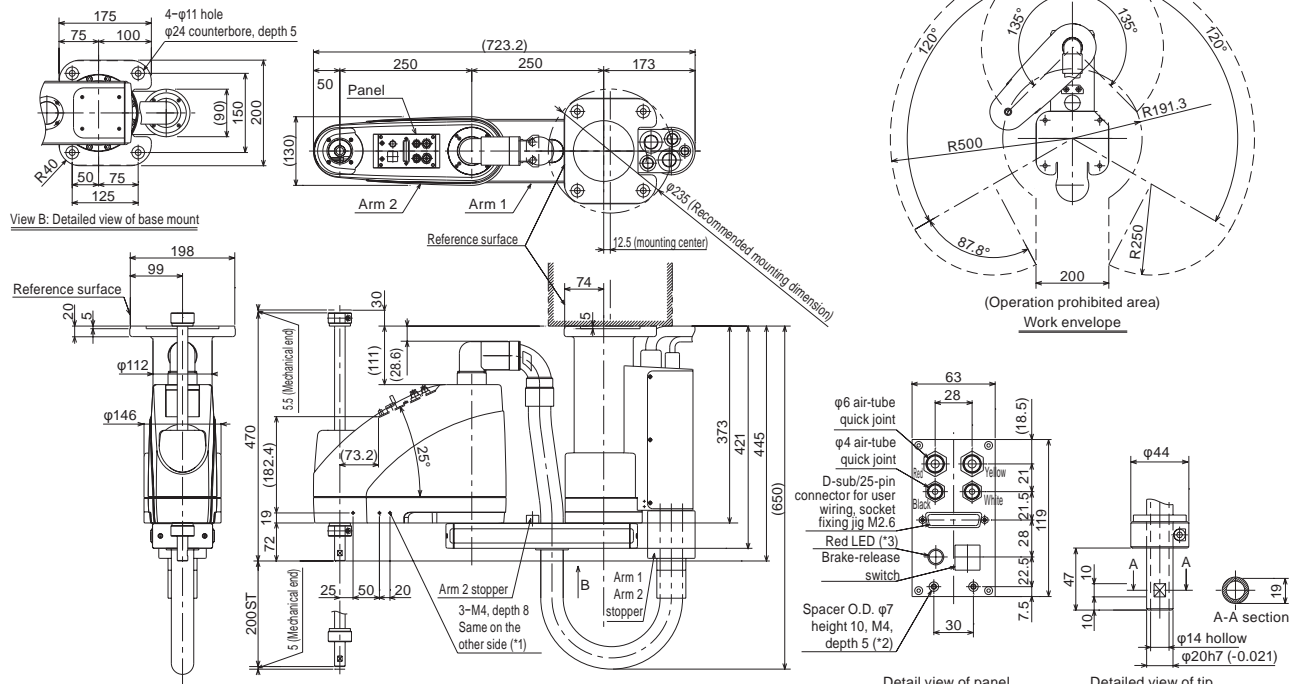

- *1: The prepared hole 3-M4, depth 8 passes through the side panel of the arm. If the mounting screw is long, make sure it does not contact internal components.
- *2: The external force applied to a spacer must not exceed 30 N in the axial direction, or 2 N·m in the rotating direction. (for each spacer)
- *3: In order to use the LED, the user must wire it so that it responds to the controller's I/O output signal by supplying 24 V DC to the applicable LED terminal in the user wiring.

- Cables/tubes
- Motor/encoder cable 5m/10m
 - Brake power cable 5m/10m
 - User Wiring Cable 5m/10m
 - Air tube (4 pcs) 0.15m

Applicable Controller Specifications

Applicable Controller	Features	Maximum I/O points (inputs/outputs)	Power-supply voltage	Reference page
XSEL-PX-##-2[3]	Maximum 6 axes, 1600 [2400] W supported	192/192 points	Single-phase [Three-phase] 230 VAC	p. 37
XSEL-QX-##-2[3]	Safety Category 4 supported			

*The SCARA model with high-power specification [H] needs a 2.4 kW three-phase type controller XSEL-PX/QX-##-3.

Caution For explanations of (Note 1) through (Note 9), refer to page 7.