



EXPLOSION PROOF PAINTING ROBOTS

The K-Series line of painting robots combines high operational performance with powerful programming flexibility. With six explosion-proof models available, Kawasaki has a robot that will suit any robotic painting application, from a one robot paint cell to complete multi-robot integrated finishing systems.

KJ264 - SHELF

Payload	wrist 15 kg, arm 25 kg	Applications <ul style="list-style-type: none">• Painting
Horizontal Reach	2,640 mm	
Vertical Reach	4,607 mm	
Max. Painting Speed	1,500 mm/s	
Wrist Type	3R ø70 mm (Roll Roll Roll - hollow wrist)	



COMPREHENSIVE ROBOT LINE UP

Kawasaki offers six explosion-proof painting robot models, from the KF121 for small applications to the KJ314 for automotive inner and outer body finishing. All models are suited for hazardous environments such as spray painting and boast industry leading mean time between failures (MTBF).

HOLLOW WRIST ARMS

Hollow wrist versions of the K-Series robot arms can be fitted with internal hoses to minimize overspray that adheres to the piping, reducing the risk of contaminants in the paint finish. The inner diameter of the hollow wrist is 70 mm.

PROGRAMMING FLEXIBILITY

K-Series Robots can be programmed in two ways, via the robot teach pendant or a computer, and using one of the two Kawasaki's programming methodologies, Block Step or AS Language. The Block Step programming method eliminates time consuming program teaching with auto-path generating software. The AS Language provides the programmer ultimate flexibility via a Basic like syntax through any word processor text file. The programmer can create advanced logic, manipulate program locations in addition to creating and controlling the painting process. AS Language programs can create powerful "decision making" robots.

EASY SYSTEM INTEGRATION

Kawasaki Robotics also offers a control panel to enhance the ease of system building and interfacing with peripheral equipment such as robot traveling unit, workpiece transfer unit, rotation unit, and other devices. The control panel is an intuitive graphical interface that allows users to centrally operate and control all components of the robotic finishing system. It provides real time status information and access to production management information such as line monitoring data, data setting and modification of the coating requirements and coating unit control panel, as well as statistical data on production, errors, paint consumption, etc.

EXTENSIVE PAINTING EXPERIENCE

Over 30 years of successful robotic painting experience has enabled Kawasaki to design robots to meet the needs of today's most demanding customers. The K-Series Robots are now equipped with more advanced application functions than ever offered before, resulting in increased productivity. Our highly skilled paint systems professionals have both process and technology experience and are available to support your paint automation project, from the initial planning stage right up to equipment start-up.

MOTION RANGE & DIMENSIONS

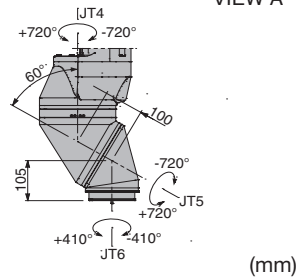
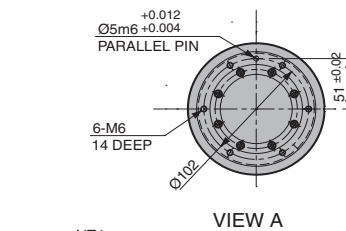
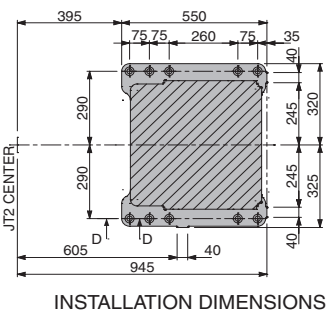
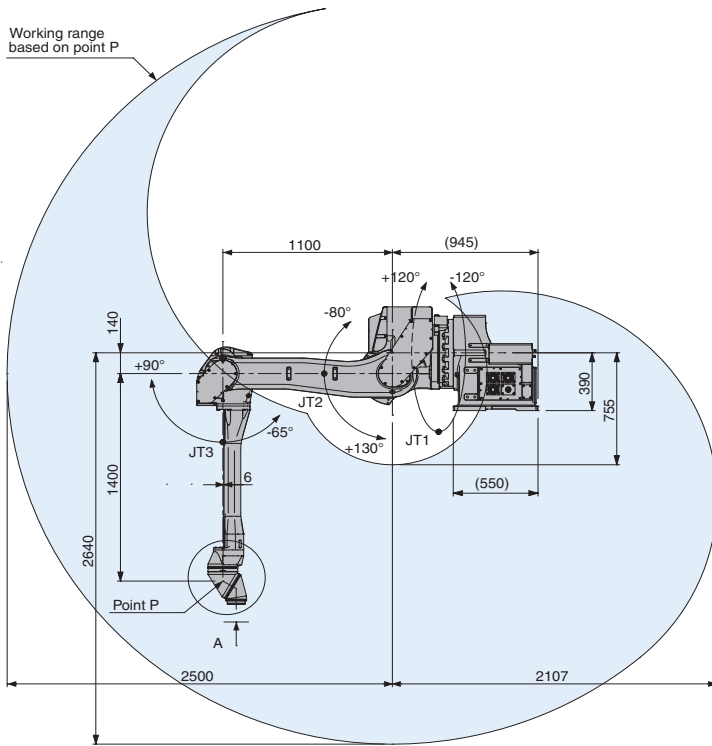

Note: Detailed drawings are available upon request.

Simple friendly

KJ264 (SHELF) SPECIFICATIONS

Type	Articulated	
Degrees of Freedom	6 axes	
Payload	Wrist 15 kg, arm 25 kg	
Horizontal Reach	2,640 mm	
Vertical Reach	4,607 mm	
Repeatability	±0.5 mm	
Maximum Painting Speed	1,500 mm/s at the center of tool mounting surface	
Wrist Type	3R ø70 mm (Roll Roll Roll - hollow wrist)	
Work Envelope (degrees)	Motion Range	
	JT1	±120°
	JT2	+130° ~ -80°
	JT3	+90° ~ -65°
	JT4	±720°
	JT5	±720°
Wrist Load Capacity	Axis	Maximum Torque
	JT4	56.2 N·m
	JT5	43.4 N·m
JT6	22.0 N·m	
Motor(s)	Brushless AC Servomotor	
	All axes	
	Adjustable mechanical stopper JT1	
Mass		
530 kg (excluding Options)		
Installation		
Shelf		
Environmental Conditions	Temperature	0 ~ 40° C
	Humidity	35 ~ 85 % (no dew, nor frost allowed)
Explosion Protection		
Pressurized and intrinsically safe Class 1, Zone 1, Group IIB & T4 certified		
Air Supply to Manipulator		
Input quantity, pressure: 0.5 Nm ³ /min., 0.4~0.7 MPa		
Clean and dry air:		
Solid material: 0.01 µm or less		
Oil content: mist separation 99.9999% or more		
Dew point: -17° C or less at atmospheric pressure		
Options		
Linear track options		
Riser (300/600 mm)		
Base plate		
Adjustable mechanical stopper JT2/JT3		
Jig set for zeroing		
Internal painting equipment:		
FGP motor (max. 1 unit)		
Solenoid valve for painting (max. 3 units)		
Electro pneumatic converter (max. 3 units)		
Upper arm cover		
Application hose cover		
Controller		
E35 (See E Controller data sheet for specifications)		

Assembly • Cutting • Dispensing • Grinding • Handling • Inspection • Packaging • Painting • Palletizing • Polishing • Tending • Welding

Kawasaki Robotics (USA), Inc.

United States
28140 Lakeview Drive
Wixom, Michigan 48393
Phone (248) 446-4100
Email sales@kri-us.com

Canada
Phone (905) 304-7784

Mexico
Phone (52) 33-3110-1895

www.kawasakirobotics.com

KJ264-H - REV02/14
© Kawasaki Robotics (USA), Inc. All rights reserved.
Technical specifications subject to change without notice.