

Motor Flanges

LinMot PF motor flanges allow simple and rapid mounting of LinMot P linear motors. The clamp plate design allows rapid and simple mounting/dismounting of linear motors, without removing the flange from the motor.

An appropriate flange, with the correct length, is available for each linear motor family. This not only ensures secure mechanical mounting, but also guarantees optimal cooling of the linear motor.

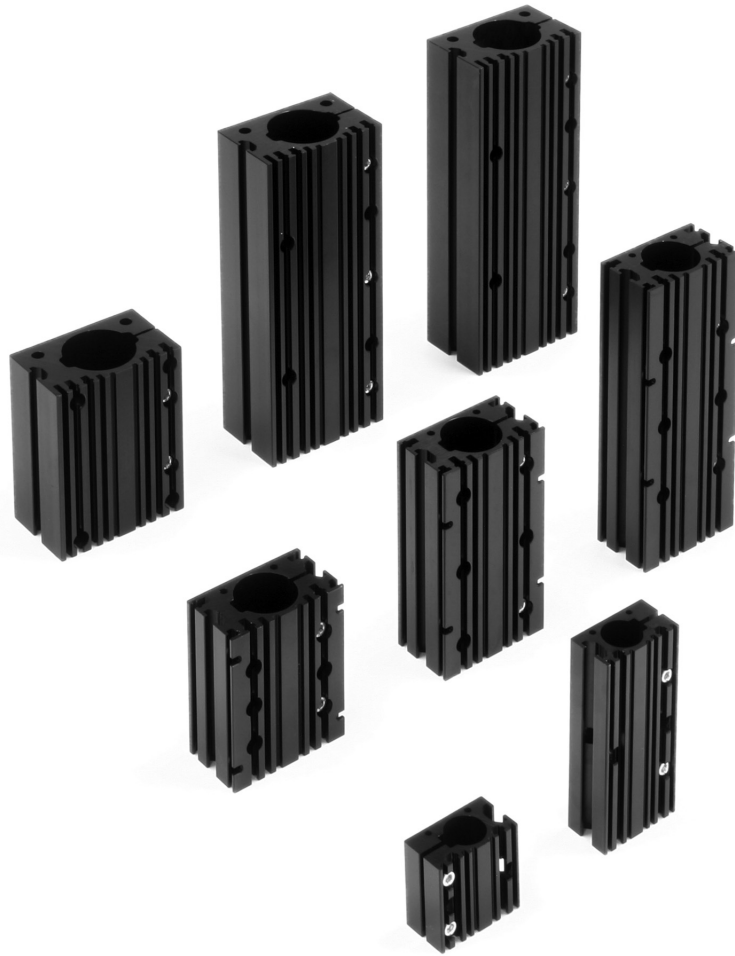

Stator Mounting

The same flange is used for stators with cable exits or connector housings. The stator is secured in the flange with clamping screws, so that the stator is clamped over a large area.

When the stator is mounted, the maximum screw torque should be observed and not exceeded.

Clamping over a large area, practically across the entire length of the stator, as well as the cooling fins on the flange, ensure optimal cooling of the linear motor.

Flange Mount Option

Depending on the application and installation space, the flanges can be mounted horizontally or vertically.

For horizontal installation, the flange is secured using screws in the through holes.

For vertical mounting, it is attached with T-nuts, using the T-slot on the narrow side of the flange.

Additional T-slots on the upper side of the flange allow accessories to be mounted easily.

Optional Fan

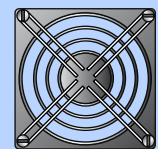
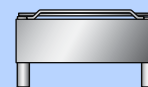

With an optional fan, the effective force of the linear motor can be nearly doubled.

Mounting with Screwholes

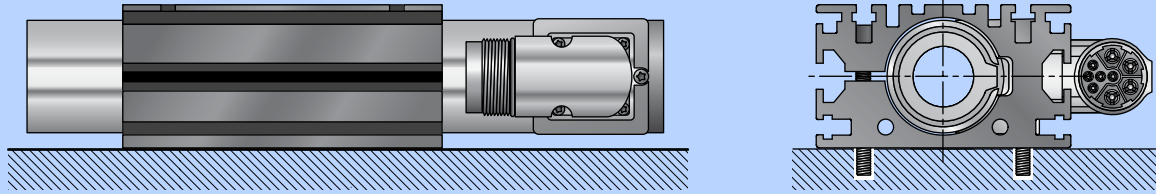

Mounting with T-Nut

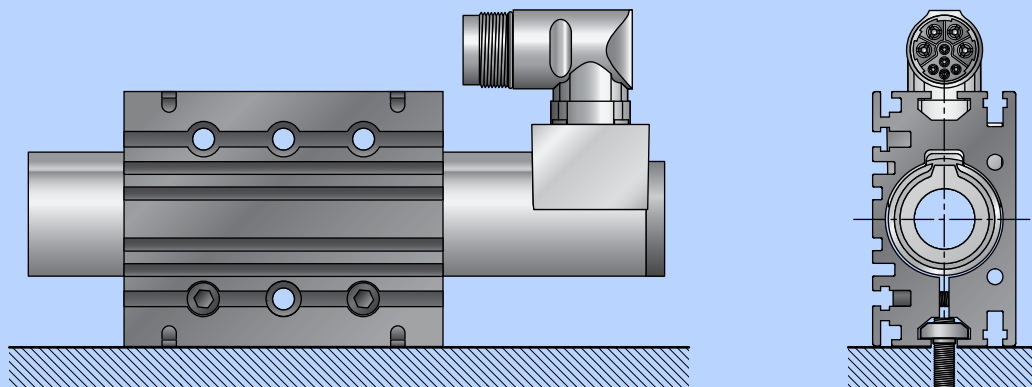

Ordering information

Item	Description	Part Number
PF02-23x50	Flange for Linear Motors P01-23x80	0150-2102
PF02-23x120	Flange for Linear Motors P01-23x160	0150-2103
PF02-23x170	Flange for Linear Motors P01-23x160	0150-2117
PF02-37x100	Flange for Linear Motors P01-37x120	0150-1998
PF02-37x140	Flange for Linear Motors P01-37x120	0150-2105
PF02-37x200	Flange for Linear Motors P01-37x240	0150-1999
PF01-48x120	Flange for Linear Motors P01-48x240	0150-1976
PF01-48x226	Flange for Linear Motors P01-48x240	0150-2108
PF01-48x346	Flange for Linear Motors P01-48x360	0150-2145

PF02-23

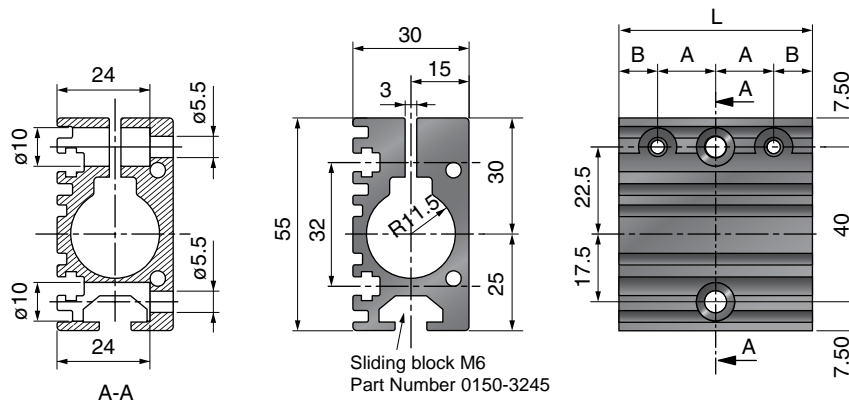

Max. torque for clamp plate screws: 4Nm

Sliding block M6
Part Number 0150-3245

Item	Description	L [mm]	A [mm]	B [mm]	Weight [g]	Part Number
PF02-23x50	Flange 23x50 mm	50	15	10	115	0150-2102
PF02-23x120	Flange 23x120 mm	120	30	30	280	0150-2103
PF02-23x170	Flange 23x170 mm	170	45	40	390	0150-2117

Optional Fan for PF02-23

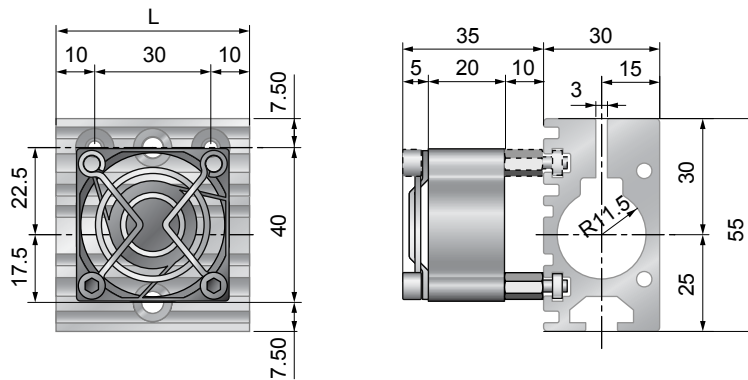

Fan supply:
24VDC, 70mA

Air flow:
15m³/h

Item	Description	Part Number
HV01-23	Fan kit for H01-23 and PF02-23	0150-5050

Flange profile PF02-23 per meter

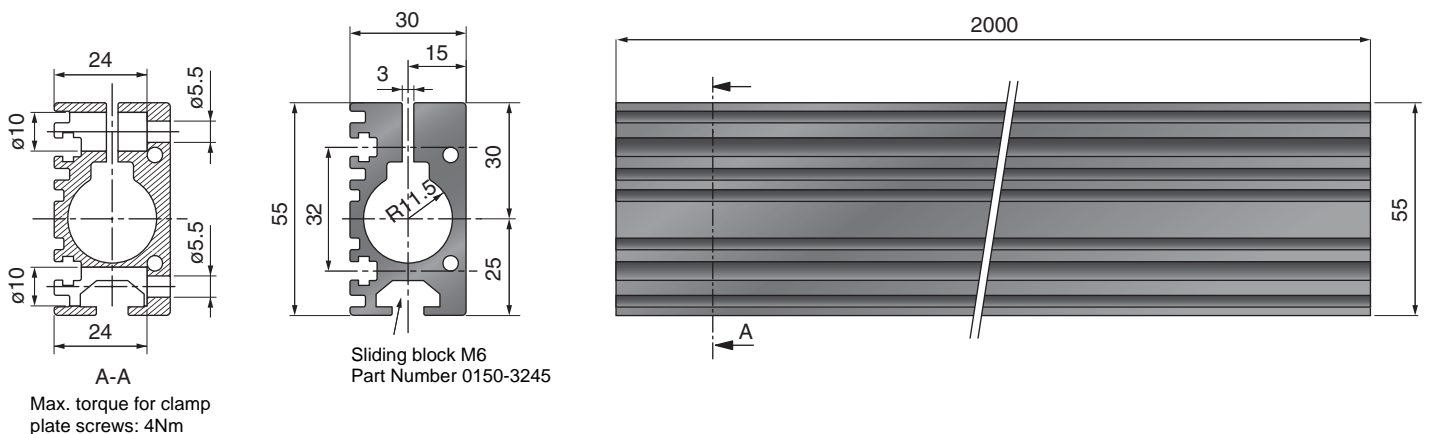

Max. torque for clamp plate screws: 4Nm

Sliding block M6
Part Number 0150-3245

Item	Description	Part Number
PF02-23 Flange profile	PF02-23 Flange profil per meter	0150-2101

PF02-37

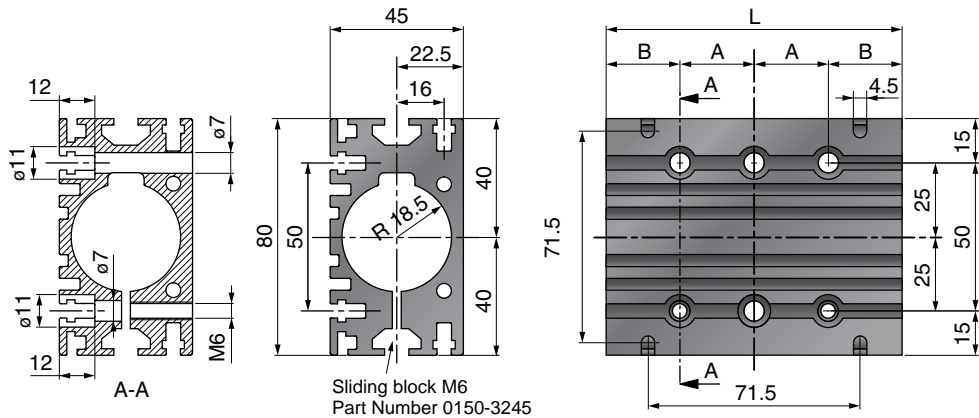

Max. torque for clamp plate screws: 8Nm

Sliding block M6
Part Number 0150-3245

Item	Description	L [mm]	A [mm]	B [mm]	Weight [g]	Part Number
PF02-37x100	Flange 37x100 mm	100	25	25	450	0150-1998
PF02-37x140	Flange 37x140 mm	140	50	20	630	0150-2105
PF02-37x200	Flange 37x200 mm	200	50	50	920	0150-1999

Optional Fan for PF02-37

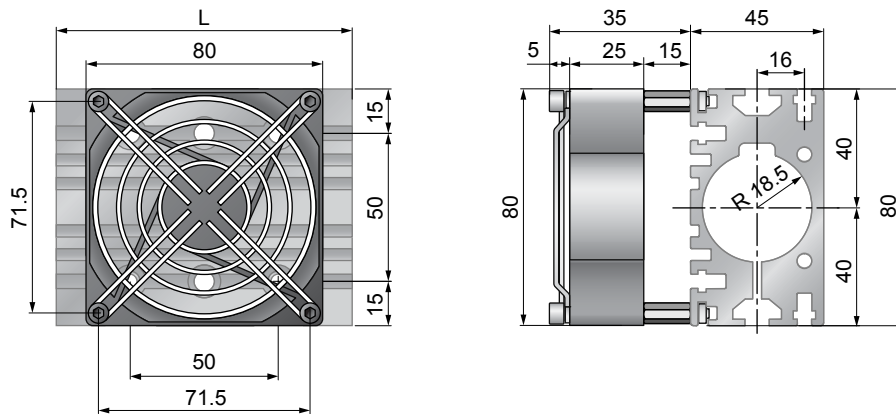

Fan supply:
24VDC, 120mA

Air flow:
80m³/h

Item	Description	Part Number
HV01-37/48	Fan kit for H01-37, B01-37 and PF02-37	0150-5051

Flange profile PF02-37 per meter

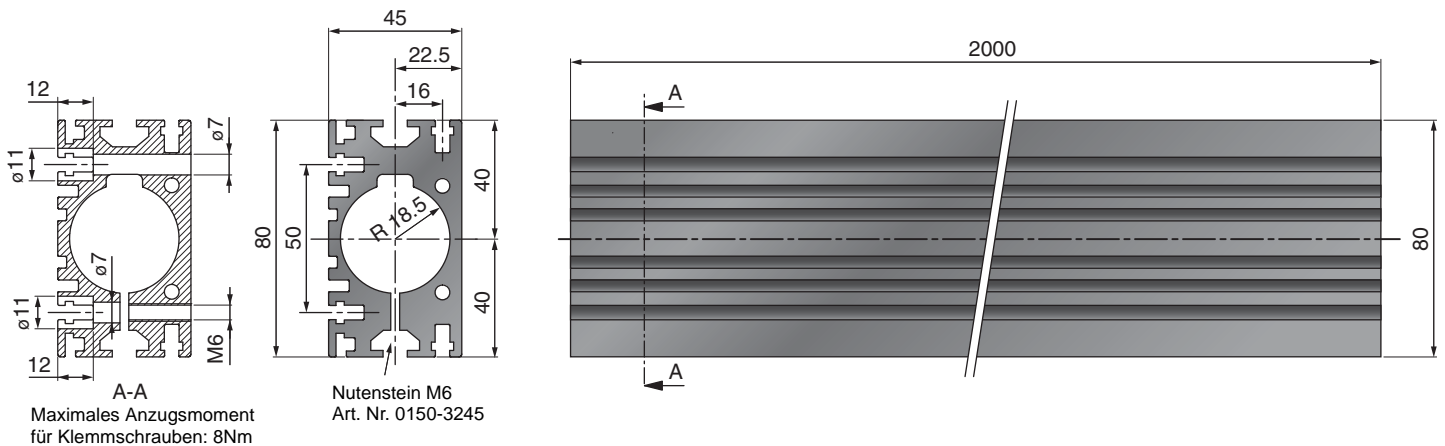

A-A
Maximales Anzugsmoment
für Klemmschrauben: 8Nm

Nutenstein M6
Art. Nr. 0150-3245

Item	Description	Part Number
PF02-37 Flange profile	PF02-37 Flange profile per meter	0150-1997

PF01-48

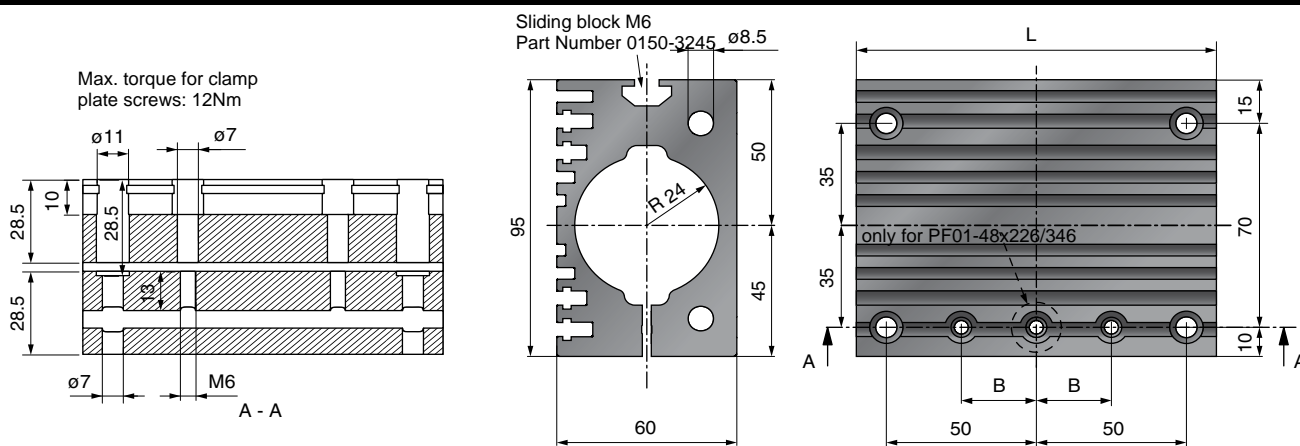

Item	Description	L [mm]	B [mm]	Weight [g]	Part Number
PF01-48x120	Flange 48x120 mm	120	25	970	0150-1976
PF01-48x226	Flange 48x226 mm	226	85	1850	0150-2108
PF01-48x346	Flange 48x346 mm	346	100 (Details p. 189)	2650	0150-2145

Optional Fan for PF01-48

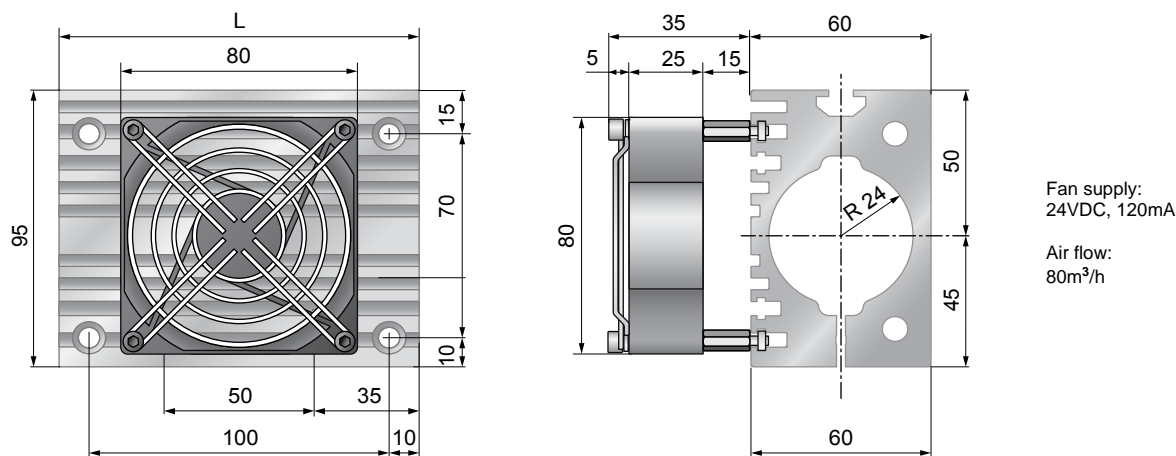

Item	Description	Part Number
HV01-37/48	Fan kit for H01-48, B01-48 and PF01-48	0150-5051

Flange profile PF01-48 per meter

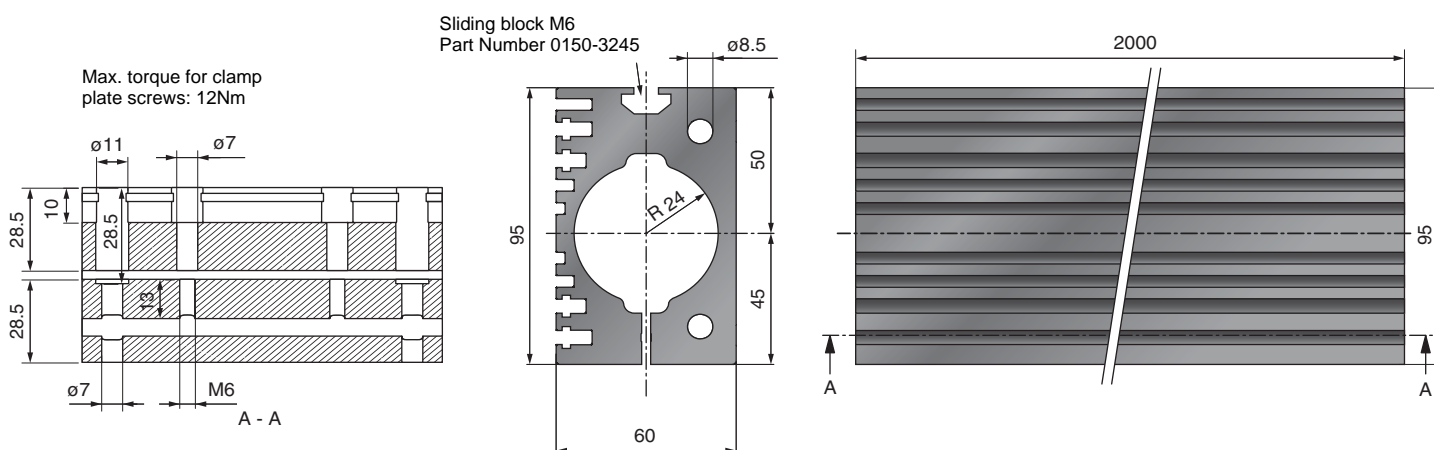

Item	Description	Part Number
PF01-48 Flange profile	PF01-48 Flange profile per meter	0150-2104